

Dimensions (1-stage, Ratio $i=4\sim 10$)

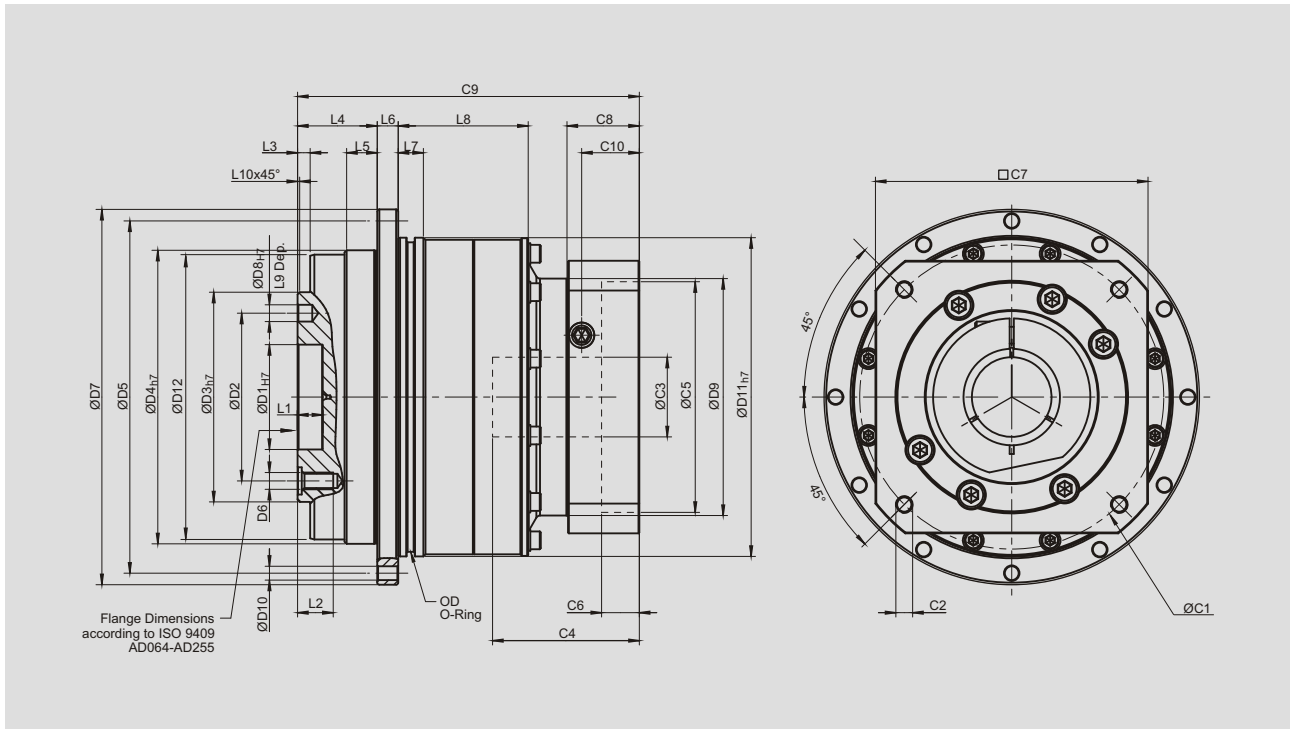

[unit: mm]

Dimension	AD047	AD064	AD090	AD110	AD140	AD200	AD255
D1 _{H7}	12	20	31.5	40	50	80	100
D2	20	31.5	50	63	80	125	140
D3 _{h7}	28	40	63	80	100	160	180
D4 _{h7}	47	64	90	110	140	200	255
D5	67	79	109	135	168	233	280
D6	4 x M3 x 0.5P	7 x M5 x 0.8P	7 x M6 x 1P	11 x M6 x 1P	11 x M8 x 1.25P	11 x M10 x 1.5P	12 x M16 x 2P
D7	72	86	118	145	179	247	300
D8 _{H7}	3	5	6	6	8	10	12
D9	45.5	55	77	90	113	138	175
D10	8 x 3.4	8 x 4.5	8 x 5.5	8 x 5.5	12 x 6.6	12 x 9	16 x 13.5
D11 _{h7}	60	70	95	120	152	212	255
D12	46.2	63.2	89.2	109.2	139.2	199.2	254.2
L1	4	8	12	12	12	16	20
L2	6.5	8	13.5	13.5	17	22.5	30.5
L3	3	3	6	6	6	8	12
L4	19.5	19.5	30	29	38	50	66
L5	7	7	10	10	14.6	15	20
L6	4	4	7	8	10	12	18
L7	5	7.7	8	10	12	15	20
L8	18.5	28.5	27	37	62	69.5	82
L9	4	6	7	7	7	10	10
L10	0.5	0.5	1	1	1	1	1
C1 ⁴	46	70	100	130	165	215	235
C2 ⁴	M4 x 0.7P	M5 x 0.8P	M6 x 1P	M8 x 1.25P	M10 x 1.5P	M12 x 1.75P	M12 x 1.75P
C3 ⁴	★ ≤ 11 / ≤ 12	★ ≤ 14 / ≤ 16	≤ 19 / ≤ 24	≤ 32	≤ 38	≤ 48	≤ 55
C4 ⁴	30	34	40	50	60	85	116
C5 ⁴	30	50	80	110	130	180	200
C6 ⁴	3.5	8	4	5	6	6	6
C7 ⁴	48	60	90	115	142	190	220
C8 ⁴	19.5	19	17	19.5	22.5	29	63
C9 ⁴	70	82.5	99.5	121.5	151	199.5	256.5
C10 ⁴	13.25	13.5	10.75	13	15	20.75	53.5
OD	56 x 2	66 x 2	90 x 3	110 x 3	145 x 3	200 x 5	238 x 5

4. C1~C10 are motor specific dimensions (metric std shown). Refer to Apexdyna.com and Design Tool to view your specific motor mounting system.

★ AD047 ratio 5, 10 offers C3 ≤ 12 option. ★ AD064 ratio 5, 10 offers C3 ≤ 16 option.

AD Series

Dimensions (2-stage, Ratio $i=20\sim 100$)

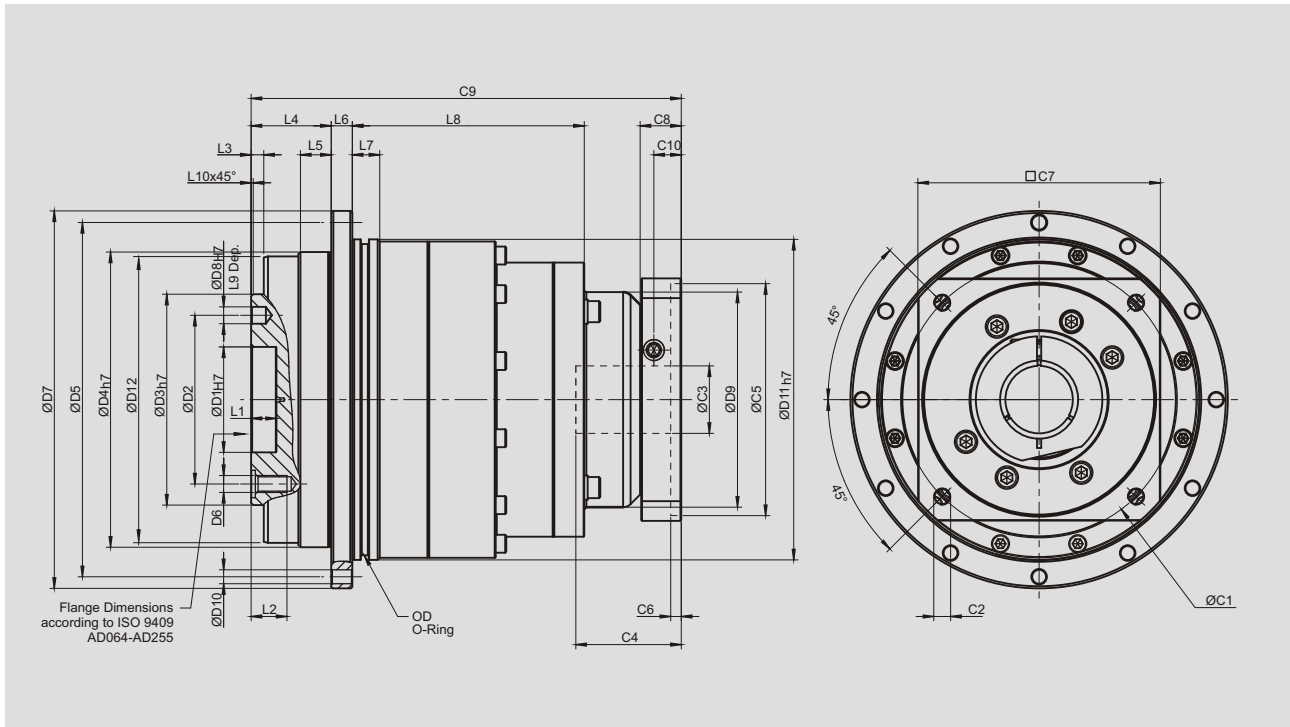

[unit: mm]

Dimension	AD047	AD064	AD090	AD110	AD140	AD200	AD255
D1 _{H7}	12	20	31.5	40	50	80	100
D2	20	31.5	50	63	80	125	140
D3 _{H7}	28	40	63	80	100	160	180
D4 _{H7}	47	64	90	110	140	200	255
D5	67	79	109	135	168	233	280
D6	4 x M3 x 0.5P	7 x M5 x 0.8P	7 x M6 x 1P	11 x M6 x 1P	11 x M8 x 1.25P	11 x M10 x 1.5P	12 x M16 x 2P
D7	72	86	118	145	179	247	300
D8 _{H7}	3	5	6	6	8	10	12
D9	45.5	45.5	53.4	77	102	125	160
D10	8 x 3.4	8 x 4.5	8 x 5.5	8 x 5.5	12 x 6.6	12 x 9	16 x 13.5
D11 _{H7}	60	70	95	120	152	212	255
D12	46.2	63.2	89.2	109.2	139.2	199.2	254.2
L1	4	8	12	12	12	16	20
L2	6.5	8	13.5	13.5	17	22.5	30.5
L3	3	3	6	6	6	8	12
L4	19.5	19.5	30	29	38	50	66
L5	7	7	10	10	14.6	15	20
L6	4	4	7	8	10	12	18
L7	5	7.7	8	10	12	15	20
L8	54.5	65	60	87.5	110	132.5	148
L9	4	6	7	7	7	10	10
L10	0.5	0.5	1	1	1	1	1
C1 ⁵	46	46	70	100	130	165	215
C2 ⁵	M4 x 0.7P	M4 x 0.7P	M5 x 0.8P	M6 x 1P	M8 x 1.25P	M10 x 1.5P	M12 x 1.75P
C3 ⁵	≤11 / ≤12	≤11 / ≤12	≤14 / ≤15.875 / ≤16	≤19 / ≤24	≤32	≤38	≤48
C4 ⁵	30	30	34	40	50	60	85
C5 ⁵	30	30	50	80	110	130	180
C6 ⁵	3.5	3.5	8	4	5	6	6
C7 ⁵	48	48	60	90	115	142	190
C8 ⁵	19.5	19.5	19	17	19.5	22.5	29
C9 ⁵	97.5	108	134	160	204	248	311.5
C10 ⁵	13.25	13.25	13.5	10.75	13	15	20.75
OD	56 x 2	66 x 2	90 x 3	110 x 3	145 x 3	200 x 5	238 x 5

5. C1~C10 are motor specific dimensions (metric std shown). Refer to Apexdyna.com and Design Tool to view your specific motor mounting system.

AD Series

Dimensions (2-stage, Ratio $i=16,21,31,61,91$)

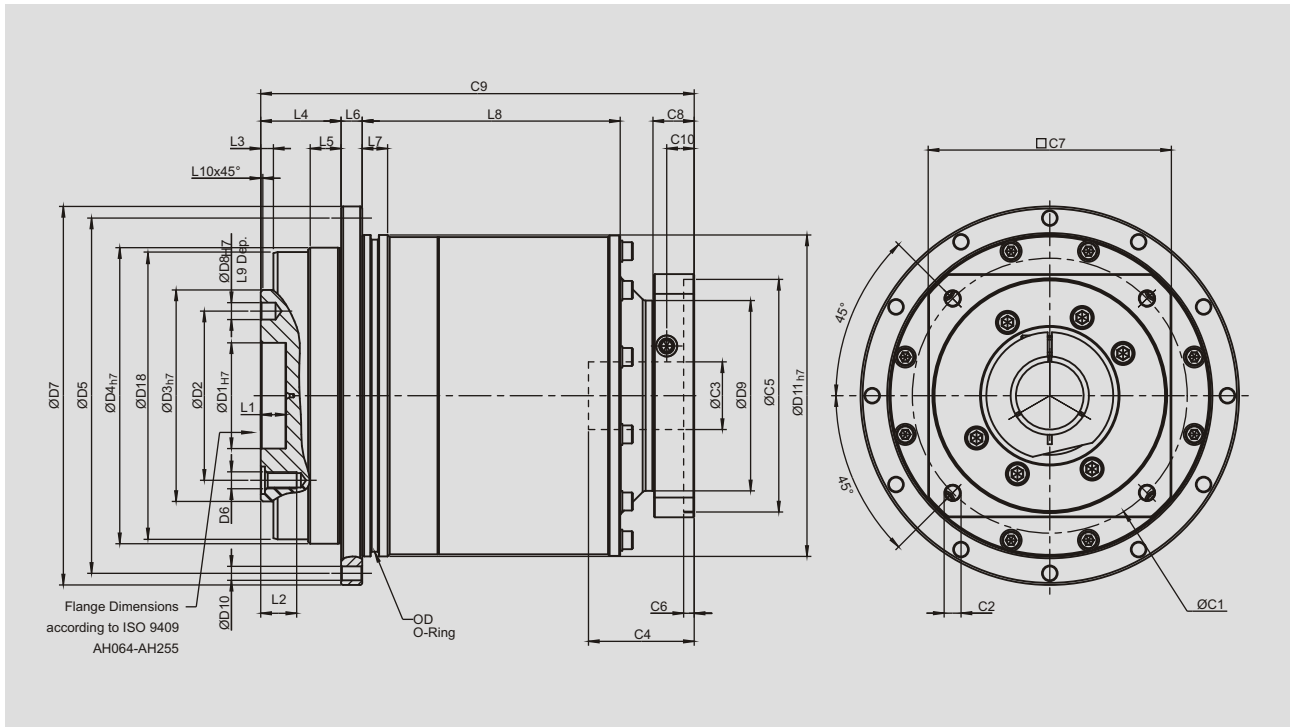

[unit: mm]

Dimension	AD047	AD064	AD090	AD110	AD140	AD200	AD255
D1 _{H7}	12	20	31.5	40	50	80	100
D2	20	31.5	50	63	80	125	140
D3 _{h7}	28	40	63	80	100	160	180
D4 _{h7}	47	64	90	110	140	200	255
D5	67	79	109	135	168	233	280
D6	4 x M3 x 0.5P	7 x M5 x 0.8P	7 x M6 x 1P	11 x M6 x 1P	11 x M8 x 1.25P	11 x M10 x 1.5P	12 x M16 x 2P
D7	72	86	118	145	179	247	300
D8 _{H7}	3	5	6	6	8	10	12
D9	45.5	45.5	55	77	90	113	138
D10	8 x 3.4	8 x 4.5	8 x 5.5	8 x 5.5	12 x 6.6	12 x 9	16 x 13.5
D11 _{h7}	60	70	95	120	152	212	255
D18	46.2	63.2	89.2	109.2	139.2	199.2	254.2
L1	4	8	12	12	12	16	20
L2	6.5	8	13.5	13.5	17	22.5	30.5
L3	3	3	6	6	6	8	12
L4	19.5	19.5	30	29	38	50	66
L5	7	7	10	10	14.6	15	20
L6	4	4	7	8	10	12	18
L7	5	7.7	8	10	12	15	20
L8	52.5	28.5	32	37	122	79.5	82
L9	4	6	7	7	7	10	10
L10	0.5	0.5	1	1	1	1	1
C1 ⁶	46	46	70	100	130	165	215
C2 ⁶	M4 x 0.7P	M4 x 0.7P	M5 x 0.8P	M6 x 1P	M8 x 1.25P	M10 x 1.5P	M12 x 1.75P
C3 ⁶	≤11 / ≤12	≤11 / ≤12	≤14 / ≤15.875 / ≤16	≤19 / ≤24	≤32	≤38	≤48
C4 ⁶	30	30	34	40	50	60	85
C5 ⁶	30	30	50	80	110	130	180
C6 ⁶	3.5	3.5	8	4	5	6	6
C7 ⁶	48	48	60	90	115	142	190
C8 ⁶	19.5	19.5	19	17	19.5	22.5	29
C9 ⁶	100	106	130.5	149	205	247.5	323
C10 ⁶	13.25	13.25	13.5	10.75	13	15	20.75
OD	56 x 2	66 x 2	90 x 3	110 x 3	145 x 3	200 x 5	238 x 5

6. C1-C10 are motor specific dimensions (metric std shown). Refer to Apexdyna.com and Design Tool to view your specific motor mounting system.

Output Dimensions

**AD 047
ADR 047
ADS 047**

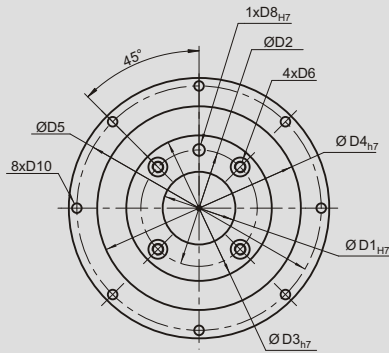

**AD 064 / AD 090
ADR 064 / ADR 090
ADS 064 / ADS 090**

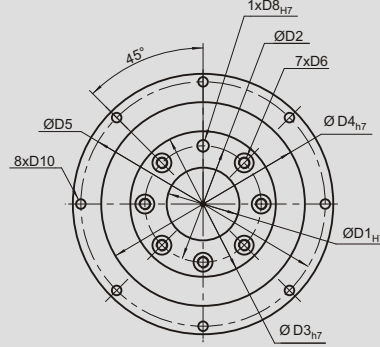

**AD 110
ADR 110
ADS 110**

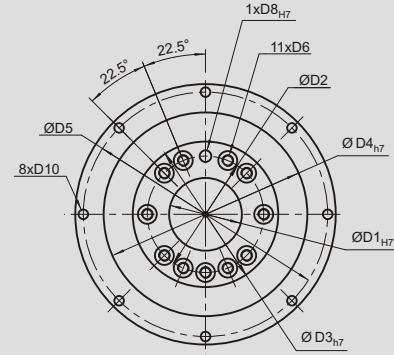

**AD 140 / AD 200
ADR 140 / ADR 200
ADS 140 / ADS 200**

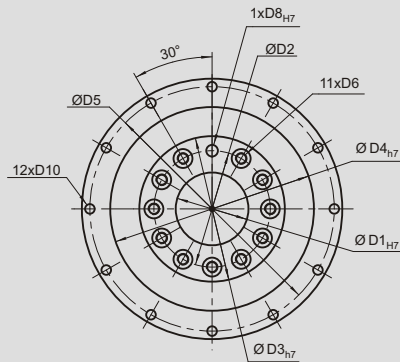

**AD 255
ADR 255
ADS 255**

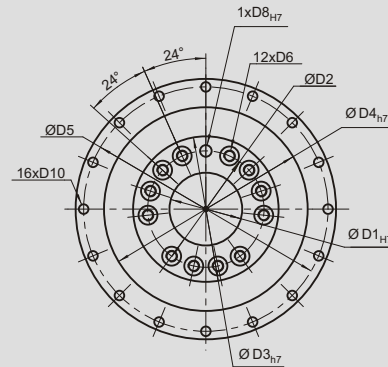

[unit: mm]

Dimension	AD047	AD064	AD090	AD110	AD140	AD200	AD255
	ADR047	ADR064	ADR090	ADR110	ADR140	ADR200	ADR255
	ADS047	ADS064	ADS090	ADS110	ADS140	ADS200	ADS255
D1 _{H7}	12	20	31.5	40	50	80	100
D2	20	31.5	50	63	80	125	140
D3 _{H7}	28	40	63	80	100	160	180
D4 _{H7}	47	64	90	110	140	200	255
D5	67	79	109	135	168	233	280
D6	M3 x 0.5P	M5 x 0.8P	M6 x 1P	M6 x 1P	M8 x 1.25P	M10 x 1.5P	M16 x 2P
D8 _{H7}	3	5	6	6	8	10	12
D10	3.4	4.5	5.5	5.5	6.6	9	13.5